

## LKF-Industrial

### Coalescence Filter

#### Translation of the original instructions



## Imprint

---

Willibrord Lösing Filterproduktion GmbH  
Am Walzwerk 2  
45527 Hattingen  
Germany

Telephone +49 2324 9460-0

Fax +49 2324 40842

e-mail [info@loesing-filter.de](mailto:info@loesing-filter.de)

Internet [www.separ.de](http://www.separ.de)

Owner Ingeborg Lösing

Procurators Boris Lösing

Marcus Hahne

Thomas Held

Commercial Register Essen District Court

Registration Number HRB 15543

# Contents

<b>Imprint</b> .....	<b>II</b>
<b>Contents</b> .....	<b>III</b>
<b>List of illustrations</b> .....	<b>V</b>
<b>List of tables</b> .....	<b>VII</b>
<b>Information about this instruction</b> .....	<b>1</b>
Storage .....	1
Replacement .....	1
Copyright .....	1
Handling instructions .....	1
Notes .....	1
Notes on safety .....	2
Notes .....	2
Embedded notes .....	3
<b>Safety information</b> .....	<b>4</b>
Intended use .....	4
Installed situation .....	4
Foreseeable faulty use and/or inappropriate handling .....	4
Basic notes on safety .....	5
<b>Technical data</b> .....	<b>6</b>
Scope of delivery .....	6
Mechanical data .....	6
Performance data .....	7
Identification .....	7
<b>Structure</b> .....	<b>8</b>
Mechanical connections .....	8
<b>Function</b> .....	<b>9</b>
<b>Storage</b> .....	<b>9</b>
<b>Transport</b> .....	<b>9</b>
<b>Installation</b> .....	<b>10</b>
Safety information .....	10
Tools .....	10
Mounting material .....	10
Mounting .....	11
Connection .....	12
Connection example 1: Filter without return flow .....	13
Connection example 2: Filter with return flow .....	14
<b>Initial commissioning</b> .....	<b>15</b>
Disassemble container .....	15
Mount water sensor .....	16
Position container .....	16
Assemble container .....	17
Fill filter .....	17
<b>Maintenance</b> .....	<b>18</b>
Safety information .....	18
Visual inspection .....	18
Assemble disassembled filter .....	19
Complete drain valve .....	19
Complete container .....	20
Complete filter element .....	20



---

Insert filter element into the container .....	20
Assemble container .....	21
Drain filter .....	22
Empty filter .....	22
Change filter element .....	23
Clean container .....	24
<b>Waste disposal .....</b>	<b>24</b>
<b>Spare parts .....</b>	<b>25</b>
<b>Accessories .....</b>	<b>25</b>



## List of illustrations

Dimensions .....	6
Rating plate .....	7
Structure .....	8
Mechanical connections .....	8
Mounting dimensions .....	11
Connection dimensions .....	12
Mechanical connections .....	12
Connection example: Filter without return flow .....	13
Connection example: Filter with return flow .....	14
Tapped hole for the water sensor .....	16
The four positions of the container .....	16
Individual parts of the filter .....	19
Admissible maximum water level .....	22





---

## List of tables

---

Explanation of the symbols on the rating plate .....	7
Spare parts .....	25
Accessories .....	25





# 1 Information about this instruction

This instruction includes information related to the life cycle of the product. It is directed toward specialist personnel who handle, install and maintain the product.

A specimen in the original language is enclosed with every translation of this instruction. Should uncertainties or discrepancies be determined in the translation, before the utilisation of the supplied product the instruction in the original language must be referred to for clarification and the manufacturer informed.

It is possible that illustrations in this instruction are used as an example and therefore do not agree exactly with the product supplied.

## 1.1 Storage

This instruction is a component part of the product. It should be stored near the product and protected against environmental impacts.

## 1.2 Replacement

If this instruction should become illegible or be lost, a replacement document can be acquired from the manufacturer. For this purpose, the reference number of the instruction must be known, which can be found in the footer on the inside margin of every page.

## 1.3 Copyright

Willibrord Lösing Filterproduktion GmbH has copyright to all documents with the Willibrord Lösing Filterproduktion GmbH company signature. Without approval of the Willibrord Lösing Filterproduktion GmbH, such documents may not be either made accessible to third parties or used in any other manner or improperly.

It is admissible, within a documentation management system, to make it available as an electronic document or a hardcopy for in-house use.

## 1.4 Handling instructions

Work and procedures are described by handling instructions:

- ▶ This is a prerequisite which must be met.
- ▶ A further prerequisite which must be met.
  1. This handling step is implemented first.
    - That is the result of the handling step.
  2. That is a further handling step.
    - = That is the result of the handling instruction.

## 1.5 Notes

Notes draw attention to situations which can lead to object damage or injuries to persons if certain rules of conduct are not adhered to.

### 1.5.1 Notes on safety

Notes on safety draw attention to dangers to health. The general safety symbol in the following examples can be replaced in concrete notes on safety by a hazard-specific symbol.

#### CAUTION



##### **Type and source of risk**

**Failure to observe the rule of conduct may result in physical injuries!**

Rule of conduct.

#### WARNING



##### **Type and source of risk**

**Failure to observe the rule of conduct may result in serious physical injuries!**

Rule of conduct.

#### DANGER



##### **Type and source of risk**

**Failure to observe the rule of conduct may result in most serious injuries or death!**

Rule of conduct.

### 1.5.2 Notes

Notes draw attention to the correct handling of the product in order to avoid material damage.

#### **NOTICE**



##### **Type and source of risk**

**Failure to observe the rule of conduct may result in property damage!**

Rule of conduct.

### 1.5.3 Embedded notes

If dangerous situations can occur during work or if inappropriate behaviour is possible, attention is drawn to this by embedded notes in handling instructions:

1. Handling step



**DANGER**

**Type and source of risk! Rule of conduct.**

2. Handling step



**WARNING**

**Type and source of risk! Rule of conduct.**

3. Handling step



**CAUTION**

**Type and source of risk! Rule of conduct.**

4. Handling step

**NOTICE**

**Type and source of risk! Rule of conduct.**

## 2 Safety information

The safety information is to be considered in performing all work.

### 2.1 Intended use

The filter is suitable for the cleaning and water-removal of light diesel oils, in accordance with DIN EN 590. It is installed in the supply flow pipe of the fuel circuit.

#### 2.1.1 Installed situation

If the supply flow of the filter is below the maximum filling level in the tank, a blocking valve must be installed between tank and filter.

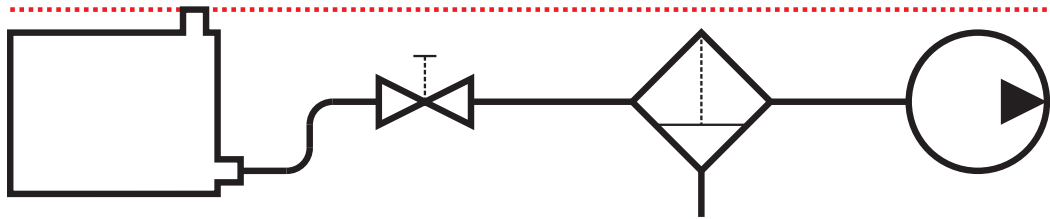

If the supply flow of the filter is above the maximum filling level in the tank, a blocking valve between tank and filter is not required as mandatory.

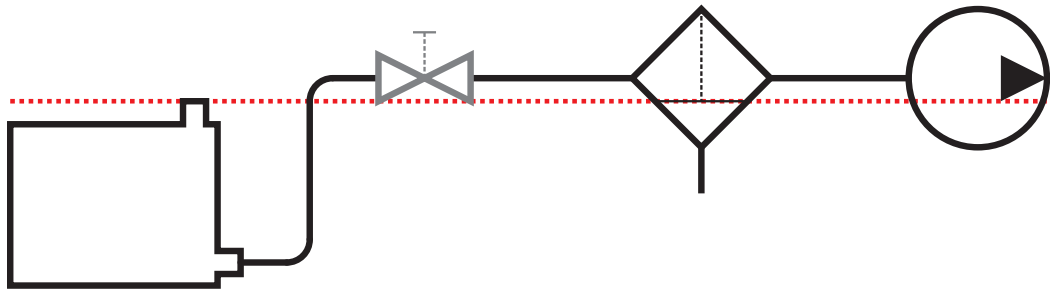

Basically we recommend to install a blocking valve.

#### 2.1.2 Foreseeable faulty use and/or inappropriate handling

The maximum flow rate of the filter must be greater than or equal to the maximum pump capacity of the fuel pump.

For the supply pipe to the filter, the following component parts may be used exclusively:

- Straight pipe pieces.
- Pipe bends with a radius which corresponds to at least three times the outer diameter of the pipe.
- Connectors and blocking elements which do not restrict the free cross-section of the pipe.

## 2.2 Basic notes on safety

### CAUTION



#### **Skin and eye irritation!**

**In case of contact with diesel oil, skin and eyes can become irritated!**

When working with fuels, the following must always be observed:

1. When indicated, wear protection gloves that protect against diesel oil.
2. When indicated, wear eye protection.
3. In case of skin contact, wash off the affected areas of the skin thoroughly and apply skin protection ointment.
4. In case of eye contact, flush the eye immediately with flowing water and then consult a doctor.

### CAUTION



#### **Environmental damage!**

**Fuel discharging into the environment can cause damage!**

When working with fuels, the following must always be observed:

1. Protect the work area so that any leaking fuel is safely collected.
2. Prior to commencement of work, exclude any leakage of fuel by suitable measures.
3. Collect any residue of leaked fuel completely with suitable materials on completion of the work.
4. Implement non-polluting waste disposal of any collected fuel, as well as materials impregnated with fuel.

### 3 Technical data

The manufacturer reserves the right to change the technical characteristics as a result of product improvements without special announcement.

#### 3.1 Scope of delivery

Filter, optionally with

- 4 M14 sealing plugs and 1 PG7 sealing plug
- 4 M14 sealing plugs and water sensor

#### 3.2 Mechanical data

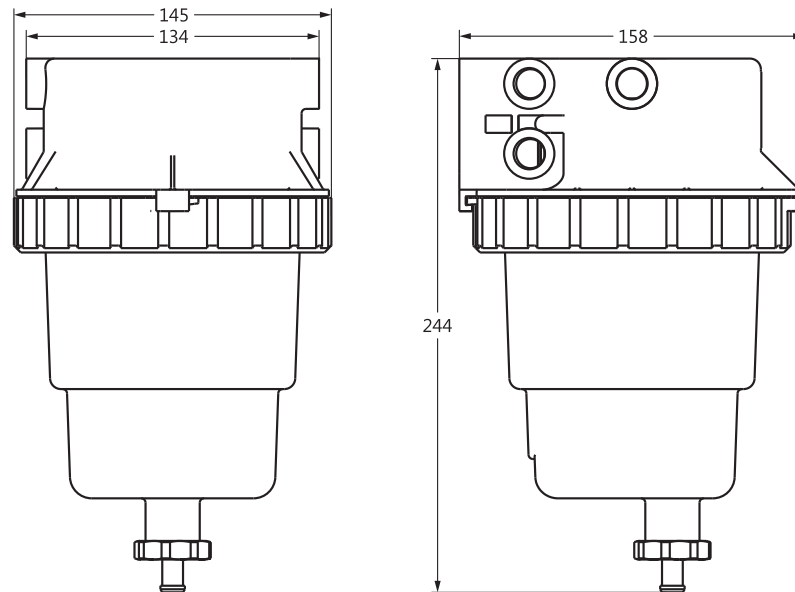

**Illustration 1:** Dimensions

Mass .....	approx. 800 g
Ambient temperature range.....	-40 °C to 85 °C
Media connectors	
Screw tap .....	M16×1.5 / ISO 9974-1
Screw-in-capable length of thread .....	≤17 mm
Tightening torque.....	15 Nm ±1 Nm
Water sensor connector	
Internal thread .....	PG7
Tightening torque.....	screw in manually until the limit stop is reached

### 3.3 Performance data

Performance data items are limit values. By the integration of the filter into an existing infrastructure, the indicated performance data can be limited under certain circumstances.

- Volume flow . . . . . ≤8 l/min
- Operating pressure (with reference to ambient pressure)
  - Continuous pressure . . . . . -0.8 bar to 1.5 bar
  - Maximum pressure . . . . . 2 bar ≤15 s
- Inflow-outflow differential pressure . . . . . ≤500 mbar

### 3.4 Identification



Illustration 2: Rating plate

1	Type designation	4	QR code for the downloading of the instruction
2	Address of the manufacturer	5	Performance data
3	Serial number		

Table 1: Explanation of the symbols on the rating plate

Symbol	Meaning
	Special waste, dispose of environmentally correctly
	Suitable only for diesel oil
	The device is equipped with a transponder which is activated with a radio frequency
Technical data	Technical data
Date of production	Date of manufacture
Serial no	Serial number
Filling volume	Filling volume of the filter
Flow rate	Volume flow
Temperature range	Ambient temperature range
Instructions	Note on the QR code for the downloading of the instructions

## 4 Structure

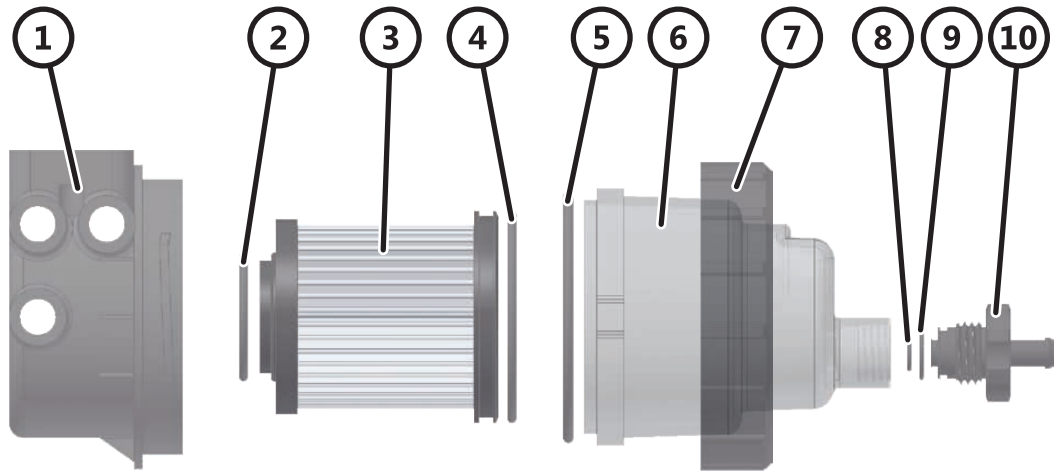

Illustration 3: Structure

1	Filter body with media connectors	6	Container
2	O-ring seal filter element/filter body	7	Bayonet ring
3	Filter element	8	O-ring seal for drain valve seating
4	O-ring seal container/filter element	9	O-ring seal container/drain valve
5	O-ring seal container/filter body	10	Drain valve

### 4.1 Mechanical connections

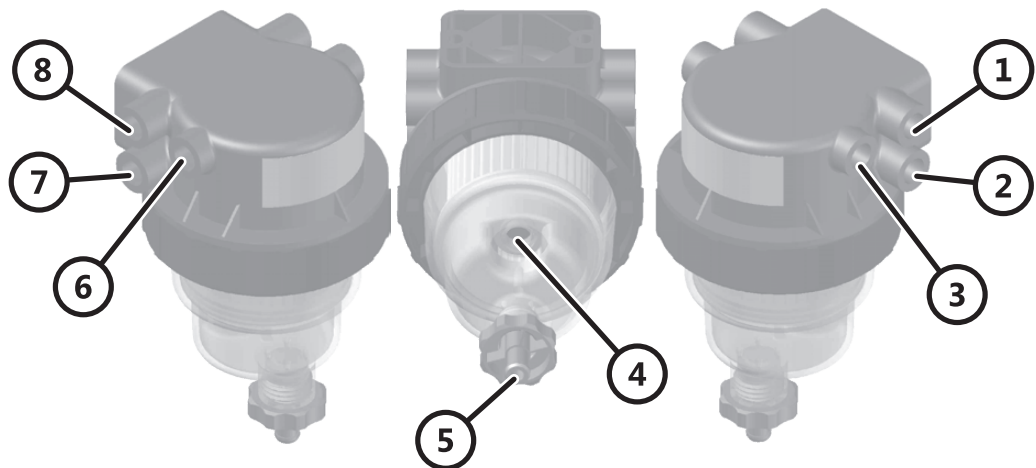

Illustration 4: Mechanical connections

1	Medium return flow, right	5	Nozzle for drain hose
2	Medium supply flow, right	6	Medium flow, left
3	Medium flow, right	7	Medium supply flow, left
4	Screw-in thread for water sensor	8	Medium return flow, left



## 5 Function

The medium suctioned by the fuel pump flows into the filter. In several stages, water and particles, which are deposited on the base of the container, are separated out by a patented process. Then suspended matter is held back by a filter element. After that the cleaned medium leaves the filter.

## 6 Storage

The filter can be stored in its original packing or alternatively wrapped dust-protected in air-cushion film.

Storage temperature range ..... -40 °C to 85 °C

Air humidity level ..... ≤80%, non-condensing

## 7 Transport

The filter can be transported in its original packing or alternatively wrapped dust-protected in air-cushion film.

When transporting, the filter may not

- be thrown about.
- be let fall.
- be impacted.
- be loaded with heavy objects.
- come in contact with sharp and/or pointed objects.

## 8 Installation

### NOTICE

#### Transport damages!

**A damaged filter can lead to consequential damage due to leaking medium!**

Before installation

1. check the filter for visible damage.
2. check the package content for completeness.
3. when indicated, replace damaged parts and extend lost parts or use a new filter.

### NOTICE

#### Dust caps!

**For the protection of the filter, all mechanical connections are sealed ex works!**

The dust caps may only be removed when installing the filter.

### 8.1 Safety information

#### CAUTION



#### Consider ambient temperature!

**Too high temperatures can damage the filter and lead to consequential damage due to leaking medium!**

Install the filter so that

- the installation surface causes no inadmissible heating.
- the filter is not in the irradiation range of hot system parts.
- when indicated, a heat shield can be mounted for the protection of the filter.

### 8.2 Tools

Torque wrench ..... AF13  
 Drill machine  
 Drill ..... 8.5 mm or 9 mm

### 8.3 Mounting material

2 machine screws  
 Thread size ..... M8  
 Length of thread ..... 12 mm to 24 mm  
 Tightening torque ..... 5 Nm ±1 Nm  
 2 spring lock washers ..... DIN 127

The length of the fastening screws must be selected so that the screw thread grips over the full length of the screw tap and does not protrude more than 12 mm in the tightened status.

## 8.4 Mounting

The filter is fixed with two machine screws which are screwed into the mounting flange.

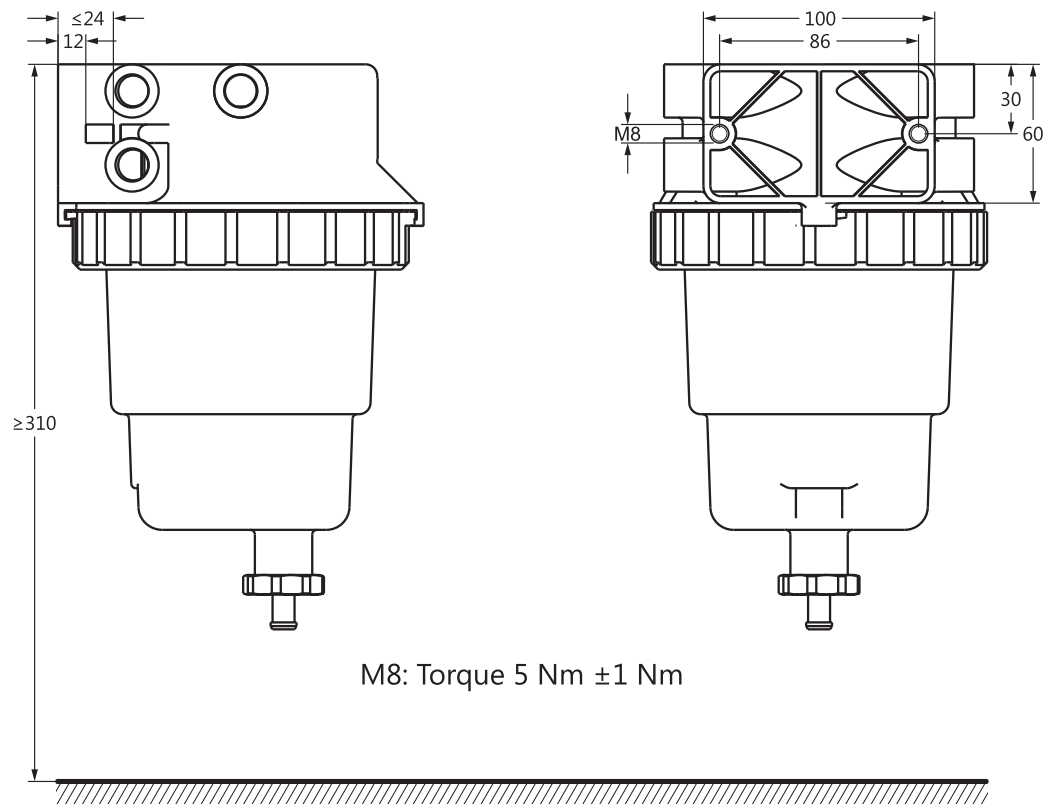

M8: Torque 5 Nm  $\pm$ 1 Nm

**Illustration 5:** Mounting dimensions

- ▶ The filter is undamaged and the package content is complete.
  - ▶ A clearance height of at least 310 mm is existing at the mounting location.
  - ▶ The filter can be mounted so that sufficient space remains under the drain nozzle for the connection of the drain hose.
  - ▶ The mounting flange does not protrude over the mounting surface.
1. Drill two holes at correct separation distance from each other and horizontal to each other.
  2. Deburr bores.
  3. Insert both screws through from the rear side of the mounting surface and screw hand-tight into the mounting flange of the filter.
  4. Align filter so that its axis is vertical.
  5. Fix filter and tighten both screws with the admissible torque.
- = The filter is mounted.

## 8.5 Connection

The media connectors are designed as tapped holes according to ISO 9974-1. Sealing plugs or connectors, which correspond to ISO 9974-2, can be screwed into them.

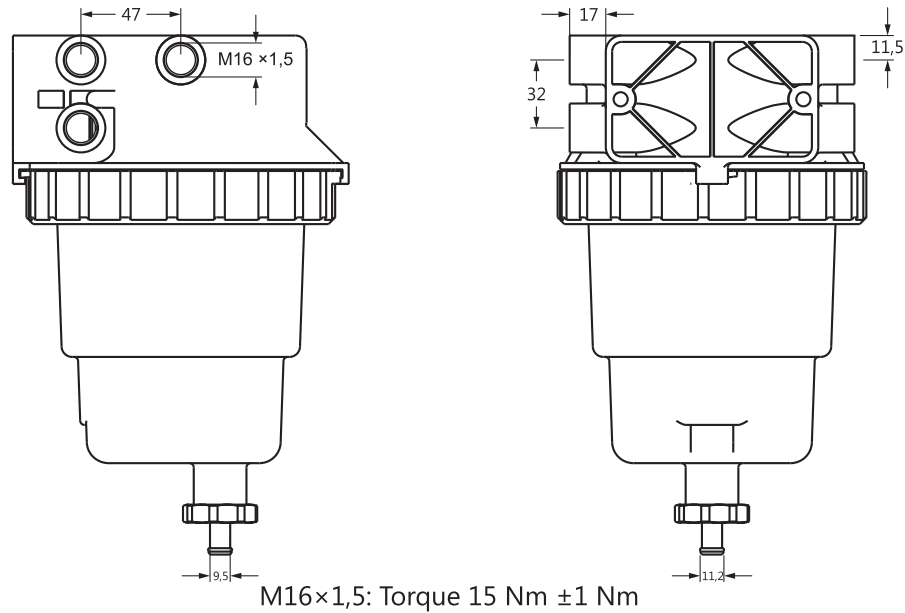

**Illustration 6:** Connection dimensions

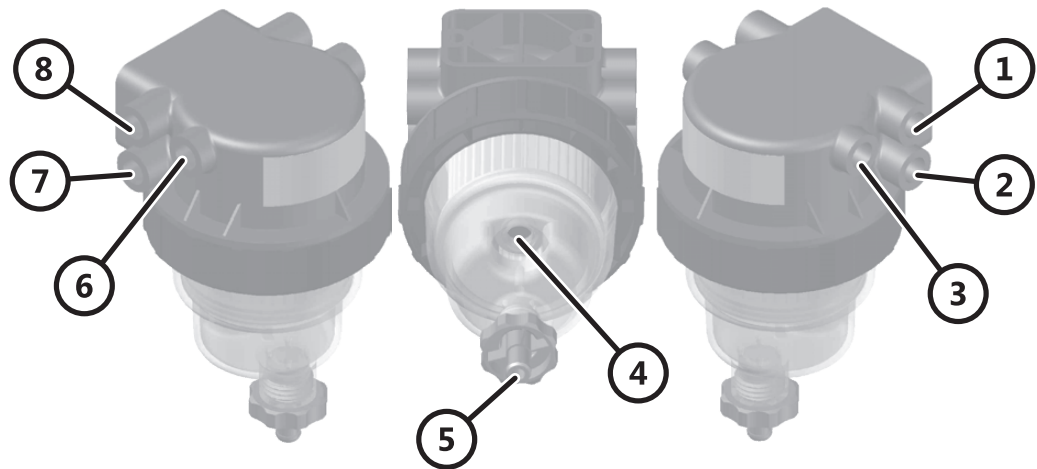

**Illustration 7:** Mechanical connections

1	Medium return flow, right	5	Nozzle for drain hose
2	Medium supply flow, right	6	Medium flow, left
3	Medium flow, right	7	Medium supply flow, left
4	Screw-in thread for water sensor	8	Medium return flow, left

### Medium supply flow

Connection for the fuel pipe from the deepest point of the tank.

### Medium flow

Connection for the fuel pipe to the injection system.

### Medium return flow

Connection for the return flow pipe of the injection system. The already warmed-up fuel in the return flow is mixed with the fuel coming from the tank.

The return flow pipe to the tank is connected to the complementary connection on the opposite side of the filter. The filter is also vented over this.

**Nozzle for drain hose**

For simpler drainage of the filter, a hose which is suitable for the medium can be slid on.

**Screw-in thread for water sensor**

A water sensor which is available as an accessory can be screwed into this screw tap, where the sensor must be evaluated by additional electronics. Thus a signal can be generated indicating when filter must be drained.

**8.5.1 Connection example 1: Filter without return flow**

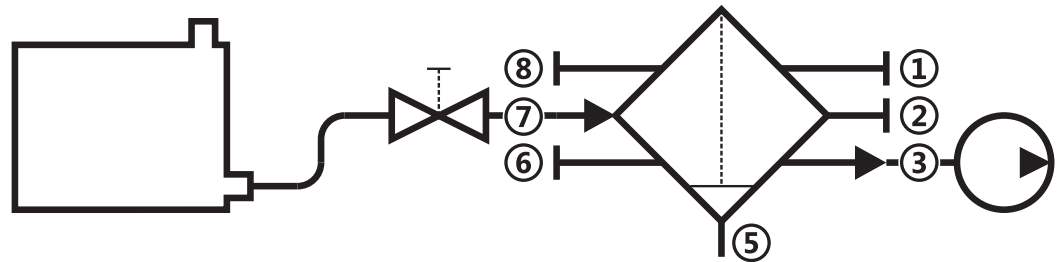

**Illustration 8:** Connection example: Filter without return flow

- ▶ The filter is mounted.
- 1. Connect the pipe from the tank to a medium supply flow **2/7**.
- 2. Seal the medium supply flow **7/2** on the opposite side of the filter with a sealing plug.
- 3. Connect the pipe from the filter to the injection system to a medium flow **3/6**.
- 4. Seal the medium flow **6/3** at the opposite side of the filter with a sealing plug.
- 5. Close off both medium return flows **1/8** with one sealing plug each.
- = The filter is connected.

### 8.5.2 Connection example 2: Filter with return flow

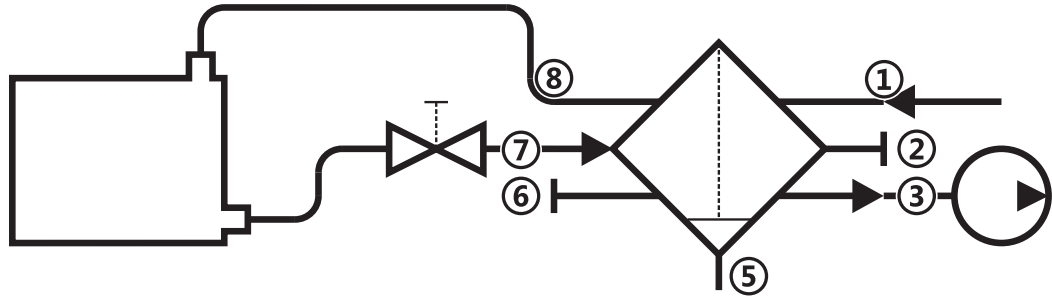

**Illustration 9:** Connection example: Filter with return flow

- The filter is mounted.
  1. Connect the pipe from the tank to a medium supply flow **2/7**.
  2. Seal the medium supply flow **7/2** on the opposite side of the filter with a sealing plug.
  3. Connect the pipe from the filter to the injection system to a medium flow **3/6**.
  4. Seal the medium flow **6/3** at the opposite side of the filter with a sealing plug.
  5. Connect the return flow pipe from the injection system to the filter to a medium return flow **1/8**.
  6. Connect the return flow pipe from the filter to the tank to a medium return flow **8/1** at the opposite side of the filter.
- = The filter is connected.

## 9 Initial commissioning

Before commissioning, possibly a water sensor must be mounted or the container must be rotated into another position.

### 9.1 Disassemble container

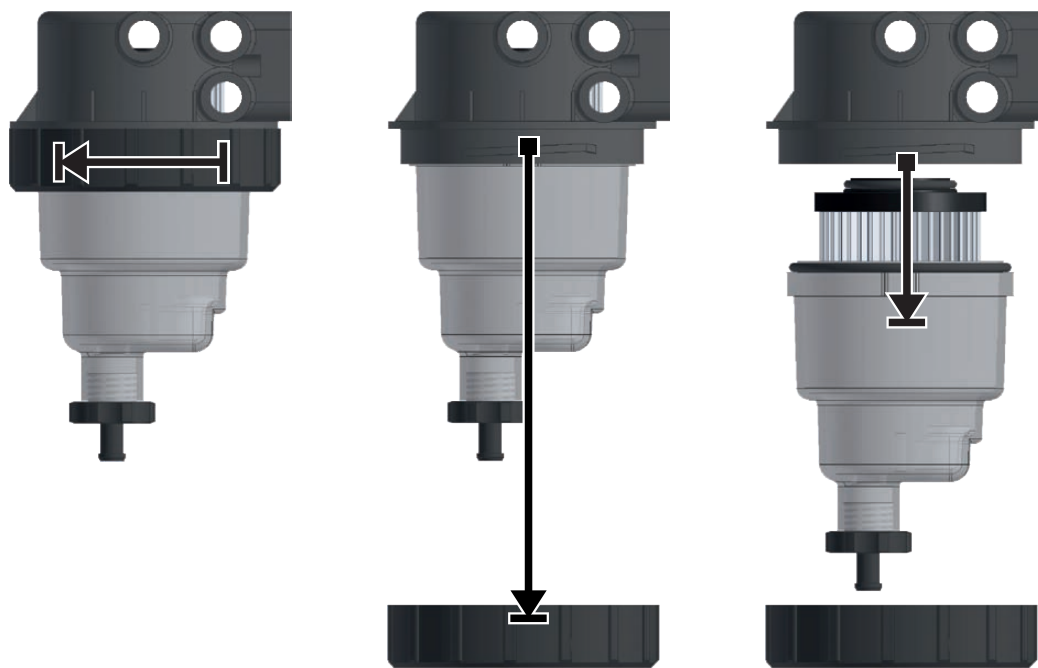

- ▶ The filter is mounted.
  - ▶ A water sensor should be assembled and/or the container should be rotated.
1. Grip the bayonet ring with both hands and loosen counter-clockwise over the resistance.
  2. Secure the container against falling down and loosen the bayonet ring completely with a quarter turn counter-clockwise.
  3. Pull off the bayonet ring down over the container and place to the side.
  4. Pull the container down from the filter body.

#### NOTICE

Ensure with pulling off the container that the filter element is pulled out from the filter body as well.

- = The container is disassembled.

## 9.2 Mount water sensor

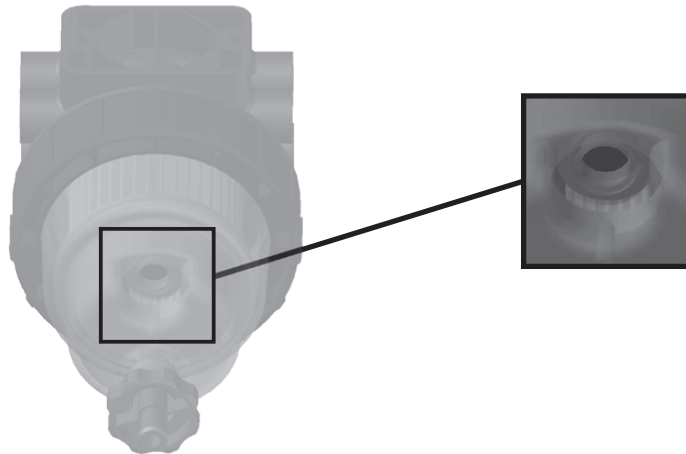
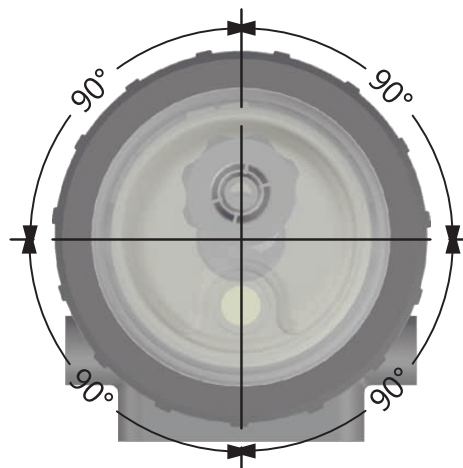

**Illustration 10:** Tapped hole for the water sensor

1. Remove the sealing plug from the container and keep safe.
  2. Slide the seal over the screw-in thread of the water sensor.
  3. Clean the sealing surface on the container with a soft cloth.
  4. Carefully screw the water sensor into the thread in the container by hand and tighten by hand until the stop is reached.
- = The water sensor is mounted.

## 9.3 Position container

The container can be inserted into four positions in the filter body. For this purpose, the container is mounted on the filter body rotated a quarter turn around the longitudinal axis in each case. The positioning is implemented over two pins arranged diametrically on the container, which are guided by two of the four slots in the filter body in each case.



**Illustration 11:** The four positions of the container



## 9.4 Assemble container

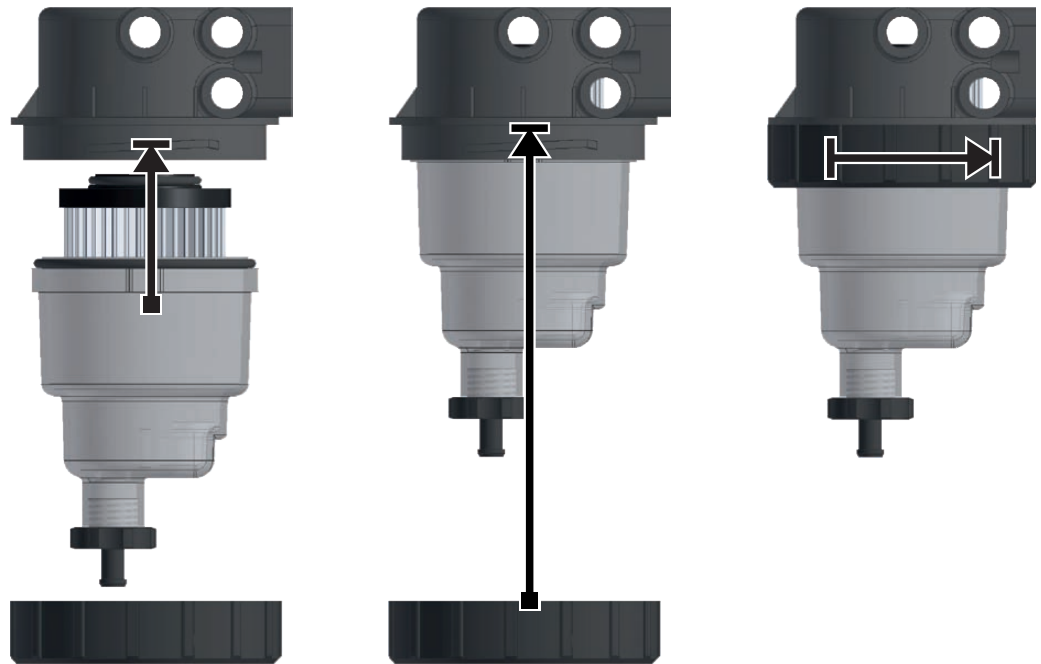

- ▶ The filter element is inserted correctly into the container.
- ▶ The sealing surfaces on the container and in the filter body are cleaned.
  1. Rotate the container around its longitudinal axis in order to get it into the approximate assembly position.
  2. Slide the container into the filter body from below. Ensure in this case that the filter element slides into the filter body without canting.
  3. Align the pins on the container by rotating so that they grip into the slots in the filter body.
  4. Using light pressure, move the container into the filter body up to the stop and hold fixed.
  5. Slide the bayonet ring over the container and screw onto the screw thread on the filter body until resistance can be felt.
  6. Take the bayonet ring with both hands and rotate fixed clockwise until it engages in its end position.
- = The container is assembled.

## 9.5 Fill filter

A suitable pump, with which fuel is suctioned from the tank, must be connected to the connection for the medium flow. As soon as the filter is filled completely with fuel and vented, the operation can be started.

## 10 Maintenance

Regular inspection of the filter ensures its permanent function and protects the engine from damage.

### 10.1 Safety information

#### CAUTION



#### **Environmental damage!**

#### **Replaceable items contaminated with fuel or cleaning agents can cause environmental damage!**

In case of maintenance work, the following must always be observed:



1. Prior to commencement of work, prevent any leakage of fuel from the tank by suitable measures.
2. Collect the fuel from the filter completely using a suitable vessel.
3. Place exchanged parts so that any possibly leaking fuel is securely absorbed.
4. Collect any residue of leaked fuel completely with suitable materials on completion of the work.
5. Ensure a non-polluting waste disposal of exchanged parts and the collected fuel, as well as materials used for cleaning.

### 10.2 Visual inspection

The time interval between visual inspections depends on the operation conditions. The following conditions shorten these intervals, in particular when they occur in combination:

- High ambient temperature
- Severe vibration and/or shaking
- Bad fuel quality

The following points are to be checked with a visual check:

1. Can any lack of sealing be determined?  
→ When indicated, localise leaking point(s) and seal.
2. Can any damage be determined (cracks, breakouts)?  
→ When indicated, replace damaged part.
3. Can dirt precipitation be determined in the container?  
→ When indicated, *Clean container* (→  24).
4. Check the water level in the container in case of filter without water sensor.  
→ When indicated, *Drain filter* (→  22).
5. In case of filter without differential pressure measurement, check the filter element for cleanliness.  
→ When indicated, *Change filter element* (→  23).

### 10.3 Assemble disassembled filter

A filter without accessories consists of the following individual parts:

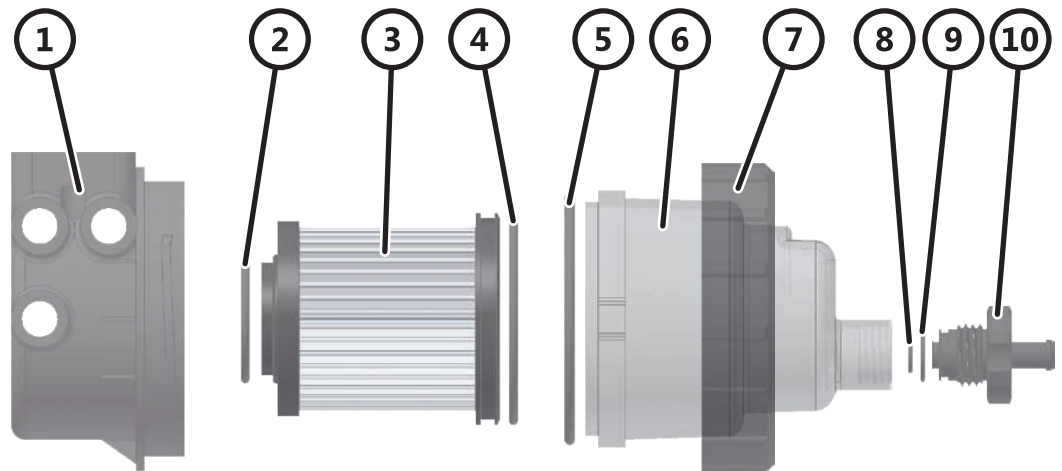

**Illustration 12:** Individual parts of the filter

1	Filter body with media connectors	6	O-ring seal filter element/filter body
2	Filter element	7	O-ring seal container/filter element
3	O-ring seal container/filter body	8	Container
4	Bayonet ring	9	O-ring seal for drain valve seating
5	O-ring seal container/drain valve	10	Drain valve

#### 10.3.1 Complete drain valve

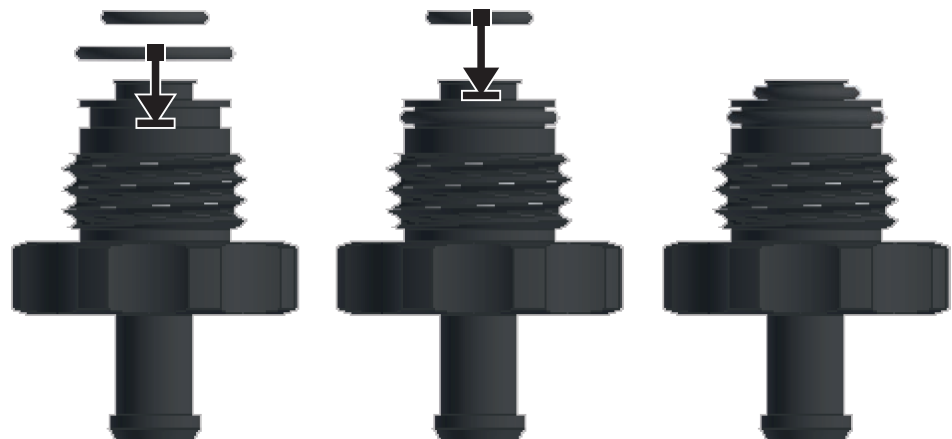

### 10.3.2 Complete container



### 10.3.3 Complete filter element



### 10.3.4 Insert filter element into the container

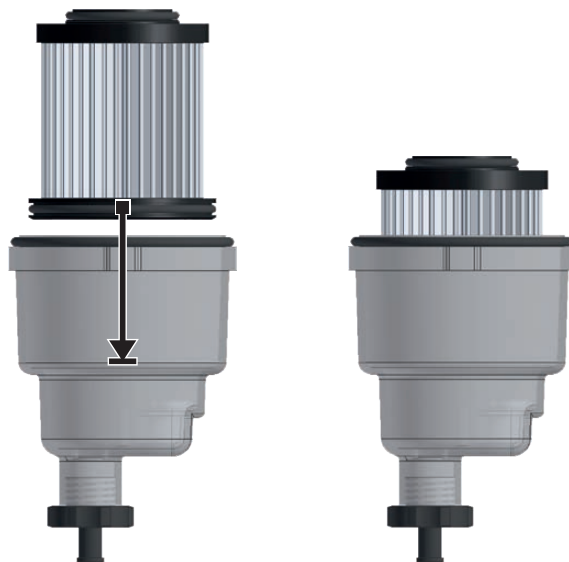

### 10.3.5 Assemble container

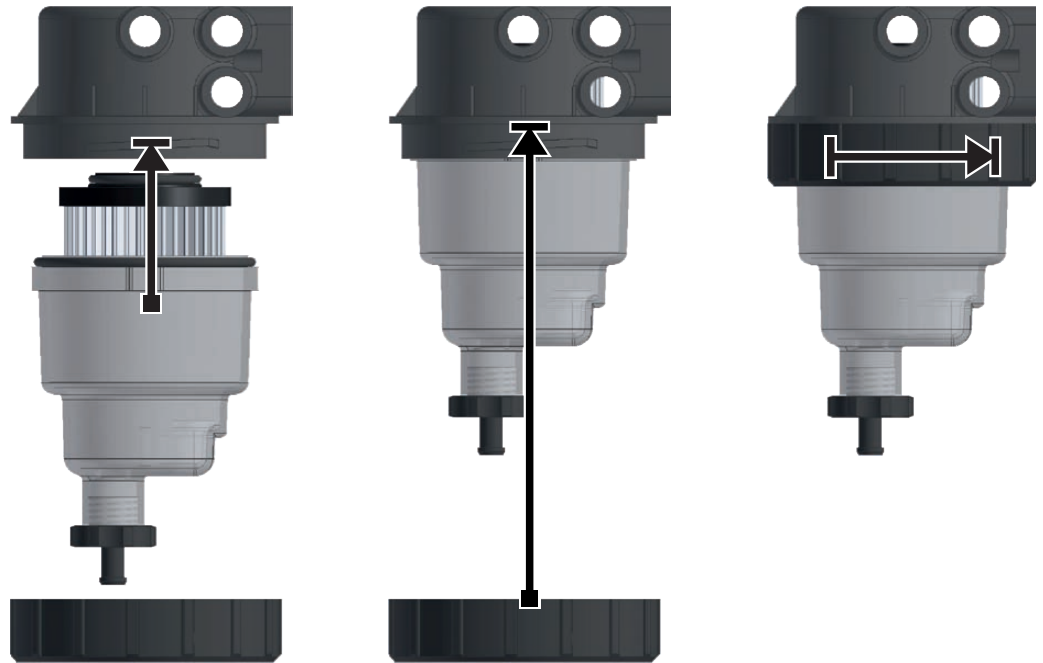

## 10.4 Drain filter

A filter must be drained immediately when

- it is equipped with a water sensor and the maximum water level is signalled.
- With the visual check, a water level which was too high was determined.

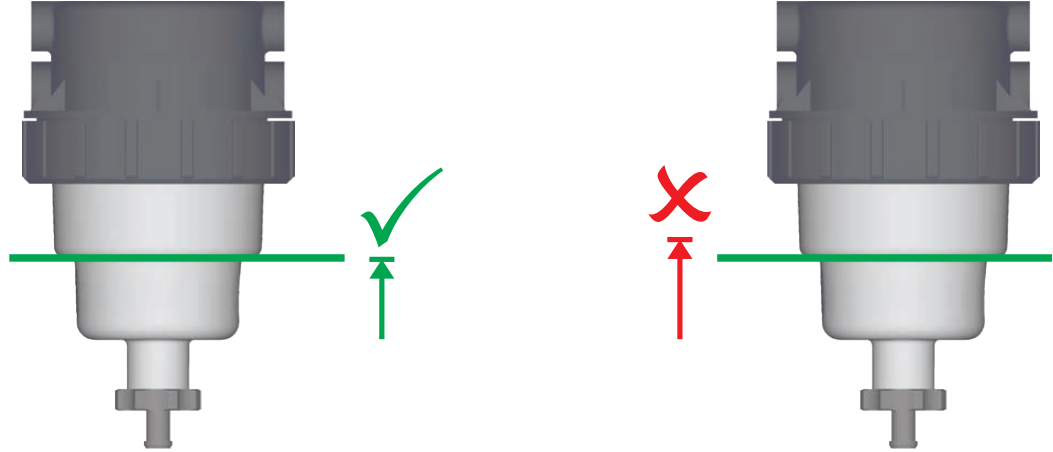

**Illustration 13:** Admissible maximum water level

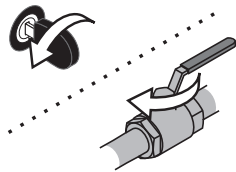

Stop machine or close supply pipe

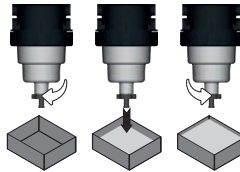

Drain off water

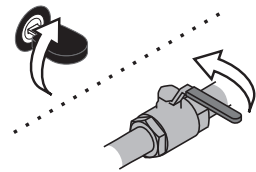

Start machine or open supply pipe

## 10.5 Empty filter

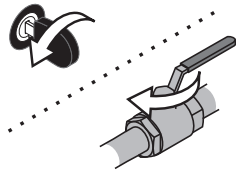

Stop machine or close supply pipe

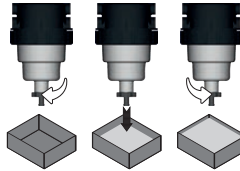

Empty filter

## 10.6 Change filter element

The filter element must be changed regularly, at the latest, 12 months after operational start-up.

Whether an earlier change is required can be determined unambiguously only with a differential pressure measurement between medium supply flow and medium run-off. If such measuring equipment is not available, the condition of the filter element must be tested regularly by a visual check. We recommend to change the filter element in case of soiling which is obviously identifiable from externally and to also clean the container in this case.

With the change of the filter element, basically new seals must be used and the sealing surfaces in the filter body, as well as in the container, cleaned free of residue. An already used filter element may not be used again.

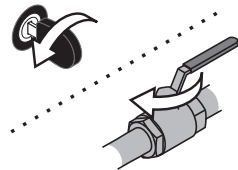

Stop machine or close supply pipe

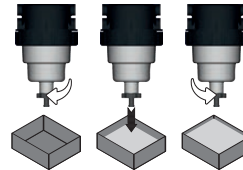

Empty filter

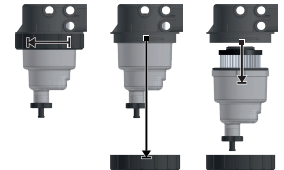

Disassemble container

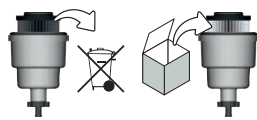

Dispose of used filter element and insert new filter element

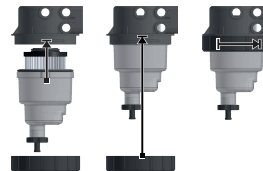

Assemble container

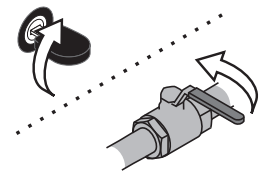

Start machine or open supply pipe

## 10.7 Clean container

### NOTICE

**Do not use any alcohol-content cleaners!**

**Alcohol changes the material properties of the container!**

1. Use clean diesel oil exclusively for the cleaning.
2. Do not use any hard or sharp-edged objects.
3. Remove contamination completely with a soft cloth.

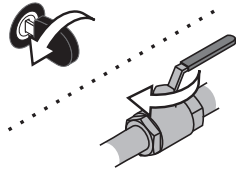

Stop machine or close supply pipe

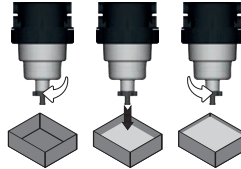

Empty filter

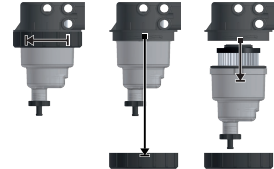

Disassemble container



Dispose of used filter element



Clean container and drain valve

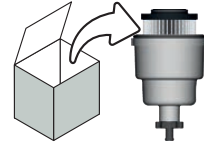

Insert new filter element

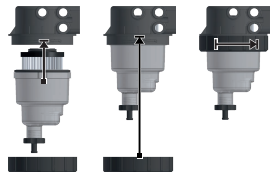

Assemble container

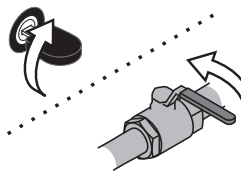

Start machine or open supply pipe









## 11 Waste disposal

All component parts of the filter must be disposed of environmentally correctly, in accordance with the legal stipulations in the country where used.



## 12 Spare parts

**Table 2:** Spare parts

Illustration	Description	REF
	LKF-Industrial with filter element 10 µm	06 3832
	LKF-Industrial with filter element 3 µm	06 3834
	LKF-Industrial with filter element 6 µm	06 3835
	LKF-Industrial, bayonet ring	06 3713
	LKF-Industrial, container with drain valve and seal set	06 3836
	LKF-Industrial, seal set, consisting of 2 × O-ring seal for drain valve 1 × O-ring seal for container	06 3837
	LKF-Industrial, filter element 10 µm with 3 O-ring seals	06 3839
	LKF-Industrial, filter element 3 µm with 3 O-ring seals	06 3841
	LKF-Industrial, filter element 6 µm with 3 O-ring seals	06 3842

## 13 Accessories

**Table 3:** Accessories

Illustration	Description	REF
	Connector plug for WSA water sensor	06 1834
	Connection plug M14×1.5 with flat seal and compression fitting	06 3747
	Sealing plug M14×1.5 with flat seal	06 3681
	Sealing plug PG7 with O-ring seal	06 1558
	WSA water sensor	06 1381







## **SEPAR Embodies Performance And Reliability**

